

## Accessories

### Programming Adapter SC/SCS for Speed Controller and Speed Control Systems, USB/RS232 interface

**Part No.: 6501.00088**

		6501.00088	
Power supply for electronics	$U_{elo}$	3,5 ... 30	V
Power supply for motor	$U_{mot}$	0 ... 30	V
Current consumption of electronics	$I_{el}$	0,1	A
Temperature range:			
– Operating temperature		0 ... + 65	°C
Dimensions and weight:			
– Dimensions (L x B x H)		80 x 65 x 31	mm
– Mass		45	g

#### General information

##### Description of connectors / controls:

<b>X1</b> Terminals for power supplies Pin 1: GND Ground connection of power supply/supplies Pin 2: $U_{elo}$ Power supply for electronics Pin 3: $U_{mot}$ Power supply for motor winding	<b>JP10</b> Jumper for selection of the source for $U_{nsoll}$ . Closed: $U_{nsoll}$ adjustable with P1.
<b>X2, X3, X6, X10</b> Terminals for motor / motor controller Pin 1: $U_P$ Power supply for motor electronics Pin 2: $U_{mot}$ Power supply for motor winding Pin 3: GND Power supply negative pole Pin 4: $U_{nsoll}$ Output for nominal speed setting 0...10V Pin 5: DIR Output for direction of rotation setting Pin 6: FG Input for speed signal from motor controller	<b>S1</b> Switch for setting the operating mode PROG mode = software update MOT mode = motor operation
<b>X5</b> RS232 connector, may optionally be used instead of X9 in PROG mode for programming	<b>S2</b> Switch for setting the direction of rotation of the motor
<b>X9</b> USB connector, may optionally be used instead of X5 in PROG mode for programming	<b>S3</b> Switch for switching the power supply $U_P$ for the electronics on/off
<b>JP1</b> Jumper can be removed and connected to an amperemeter for motor current measurement at $U_{mot}$ .	<b>P1</b> P1 is used to set $U_{nsoll}$ from 0...10V. JP10 must be closed. The power supply $U_P$ must be at least 10,5V.
<b>JP3</b> Jumper to separate power supply for electronics and motor 1-2: $U_P = U_{mot}$ » Joint power supply to electronics and motor winding via terminal $U_{mot}$ 2-3: $U_P = U_{elo}$ » Power supply to electronics via separate terminal $U_{elo}$ (separate power supply for electronics and motor winding). Power supply for programming adapter also via the terminal selected for $U_P$	<b>LED 1</b> Indicates the programming adapter is ready for operation
<b>JP9</b> Connector for external signal for $U_{nsoll}$ , e.g. PWM signal for speed setting. Note: JP10 must then be removed.	<b>LED 2</b> Indicates the external controller status. ON = ready for operation, OFF = error
	<b>Start-up</b>
	<ul style="list-style-type: none"> <li>- Connect operating voltage to X1. Use alternatively joint or separate operating voltage for electronics and motor. Note: Pay attention to correct setting of JP3.</li> <li>- Pay attention to minimum/maximum values for <math>U_{mot}</math> and <math>U_{elo}</math>.</li> <li>- S3 in position OFF; JP1 and JP10 closed.</li> <li>- Connect motor/motor controller to X2, X3, X6 or X10.</li> <li>- For PROG mode, connect to a Windows PC at X5 (null modem cable) or X9 (USB connection cable type B).</li> <li>- LED 1 and LED 2 lights up after power-on for <math>U_{mot}</math> or <math>U_{mot}</math> and <math>U_{elo}</math>.</li> </ul>
	<b>Driver installation:</b>
	If the programming adapter is to be operated via the USB connector X9, a special USB driver must be installed if using Windows XP (further details on request).

#### Dimensional drawing and connection information

scale reduced

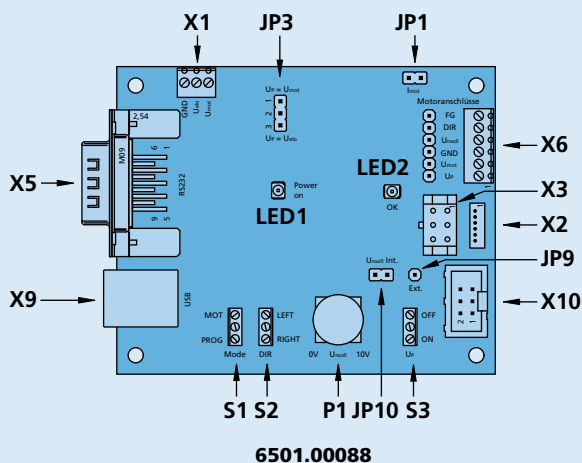

##### Connection

No.	Function
LED 1	Ready for operation
LED 2	Status external controller
<b>Terminals</b>	
X1	Power supply
X2, X3, X6, X10	Connector for motor or SC controller
X5	RS232 connector
X9	USB connector, type B
<b>Jumpers</b>	
JP1	Motor current measurement
JP3	Separation of $U_P$ from $U_{mot}$
JP9	$U_{nsoll}$ external input signal
JP10	$U_{nsoll}$ int. setting with P1
<b>Switches</b>	
S1	Operating mode
S2	Direction of motor rotation
S3	Power switch on/off
<b>Potentiometer</b>	
P1	$U_{nsoll}$ setting

##### PROG mode

Settings	
S1	PROG
S2	RIGHT
S3	OFF
<b>Terminals</b>	
P1	0V
JP1	Closed
JP10	Closed
<b>MOT mode</b>	
<b>Settings</b>	
S1	MOT
S2	RIGHT or LEFT
S3	OFF - ON
P1	0V ... 10V
JP1	Opt. current measurement
JP10	Select source for $U_{nsoll}$