

Encoders

magnetic Encoder, digital outputs,
3 channels, 256 - 4096 lines per revolution

For combination with
DC-Micromotors

Series IEH3-4096

		IEH3-256	IEH3-512	IEH3-1024	IEH3-2048	IEH3-4096	
Lines per revolution	N	256	512	1 024	2 048	4 096	
Frequency range, up to ¹⁾	f	80	160	320	640	875	kHz
Signal output, square wave		2+1 Index					Channels
Supply voltage	U_{DD}	4,5 ... 5,5					V
Current consumption, typical ²⁾	I_{DD}	typ. 25, max. 40					mA
Output current, max. ³⁾	I_{OUT}	2,5					mA
Index Pulse width ⁴⁾	P_0	90 ± 45		90 ± 65	90 ± 75		°e
Phase shift, channel A to B ⁴⁾	Φ	90 ± 45		90 ± 65	90 ± 75		°e
Signal rise/fall time, max. ($C_{LOAD} = 50$ pF)	tr/tf	0,05 / 0,05					µs
Inertia of sensor magnet	J	0,11					gcm ²
Operating temperature range		-40 ... +100					°C

¹⁾ Velocity (min⁻¹) = f (Hz) x 60/ N

²⁾ $U_{DD} = 5$ V: with unloaded outputs

³⁾ $U_{DD} = 5$ V: low logic level < 0,4 V, high logic level > 4,6 V: CMOS- and TTL compatible

⁴⁾ At 5 000 min⁻¹

For combination with Motor

Dimensional drawing A	<L1 [mm]		
1336 ... CXR - 123	47,5		
Dimensional drawing B	<L1 [mm]		
1516 ... SR	18,2		
1524 ... SR	26,2		
1717 ... SR	19,4		
1724 ... SR	26,4		
2224 ... SR	26,6		
2232 ... SR	34,6		
Dimensional drawing C	<L1 [mm]		
1727 ... CXR - 123	38,2		
1741 ... CXR - 123	52,2		

Characteristics

These incremental encoders with 3 output channels, in combination with the FAULHABER Motors, are used for the indication and control of both shaft velocity and direction of rotation as well as for positioning.

The encoder is integrated in the DC-Micromotors SR-Series and extends the overall length by only 1,4 mm.

A segmented magnetic disc provides a magnetic field which is detected and further processed by an angle sensor.

The output signals of both channels consist of a square wave signal with 90° phase shift and up to 4096 impulses and an index impulse per motor revolution.

The encoder is available with different standard resolutions.

The supply voltage for the encoder and the DC-Micromotor as well as the two channel output signals are interfaced through a ribbon cable with connector.

Details for the DC-Micromotors and suitable reduction gearheads are on separate catalogue pages.

To view our large range of accessory parts, please refer to the "Accessories" chapter.

Circuit diagram / Output signals

Output circuit

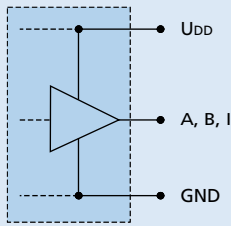

Output signals
with clockwise rotation as seen
from the shaft end

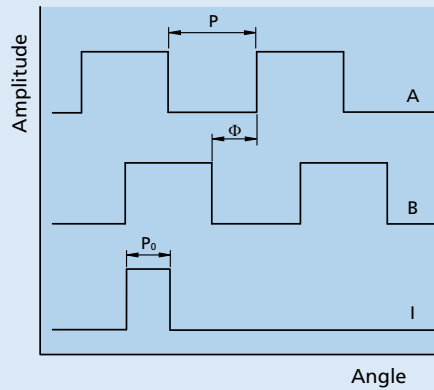

Connector information / Variants

Example product designation: 1516T006SR IEH3-4096

Option	Type	Description

Connection Encoder and Motor

No. Function

- 1 N.C.
- 2 Motor - *
- 3 Motor + *
- 4 GND
- 5 U_{DD}
- 6 Channel B
- 7 Channel A
- 8 Channel I

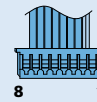

Cable
PVC-ribbon cable, 8-AWG 28, 0,09 mm²

Recommended connector
Molex PicoBlade, grid 1,25 mm

* **Note:** DC-Micromotors series CXR have separate motor leads.

Dimensional drawing A

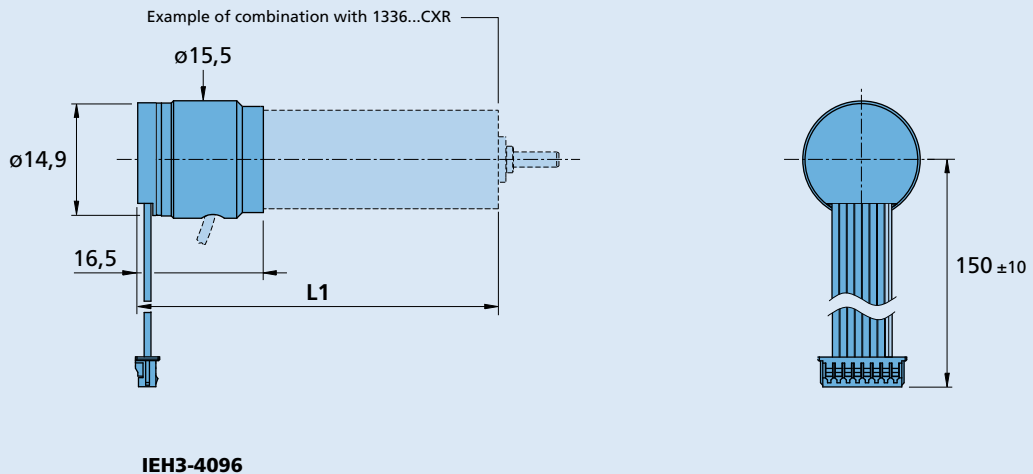

Dimensional drawing B

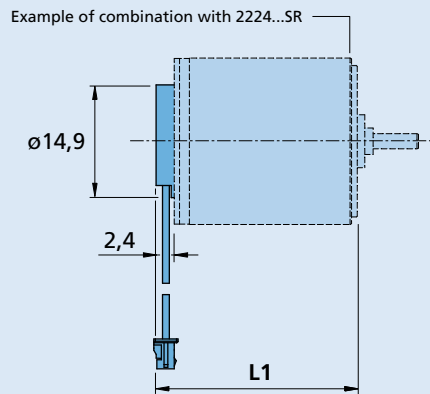

IEH3-4096

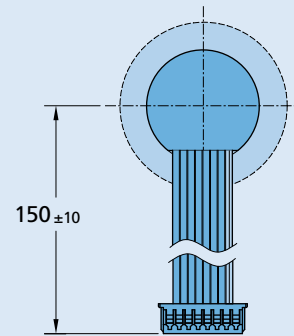

Dimensional drawing C

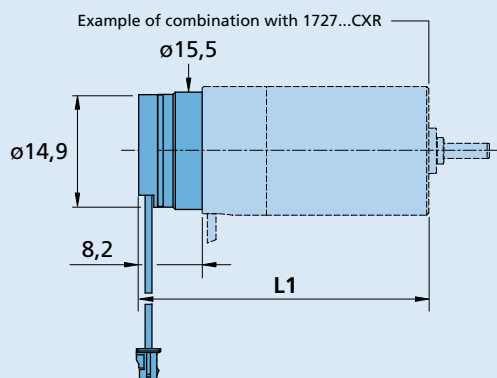

IEH3-4096

